

ZOOMLION

MACHINE 3D GRAPH

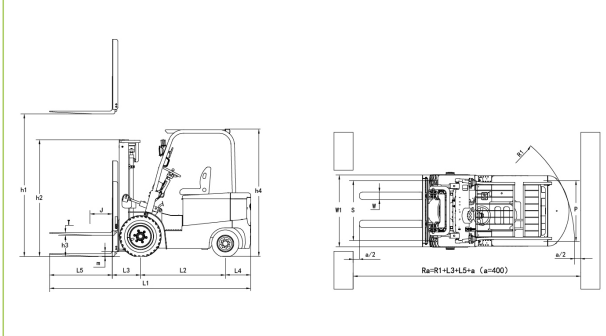

CAPACITY CHART

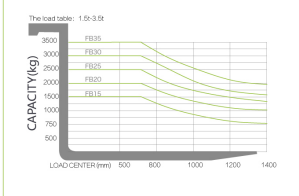

Parameter list

Model	Size(L*W*H)	Capacity(kg)	Standard Specification	Remark
FB15	990*640*480	450	90B450	Standard
FB15	990*640*480	500	90B500	high end
FB20-25	1070*810*515	630	90B630	Standard
FB20-25	1070*810*515	720	90B720H	high end
FB30	1120*900*515	520	90B520H	Standard
FB35	1120*1020*515	585	90B585H	Standard
FB35	1120*1020*515	600	90B600	high end



FB15/20/25/30/35 FOUR-WHEEL ELECTRIC FORKLIFT TRUCK



010 0010 699 (Int. +27100010699)
 info@zoomhandling.co.za
 No 92 | Cnr Dale & Pretorius Rd
 President Park | Midrand | Gauteng
 www.zoomhandling.co.za

ZOOMLION

