

ZOOMLION

MACHINE 3D GRAPH

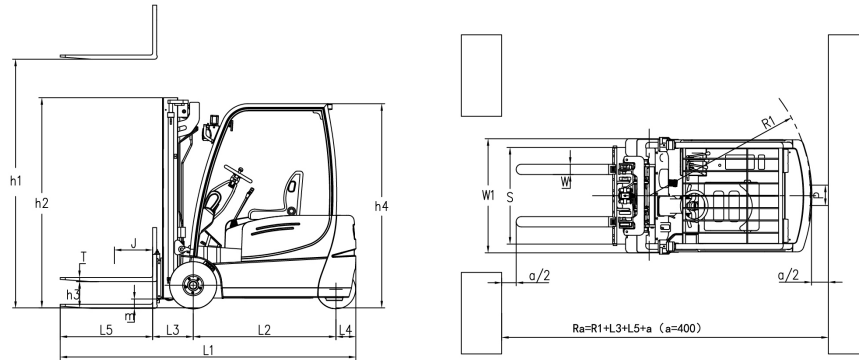

CAPACITY CHART

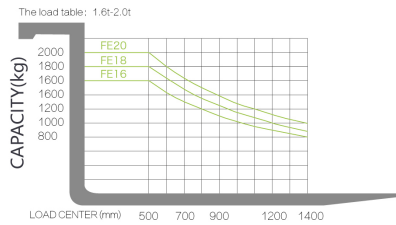

FE16/18/20

THREE-WHEEL ELECTRIC FORKLIFT TRUCK



☎ 010 0010 699 (Int. +27100010699)
 ✉ info@zoomhandling.co.za
 🏠 No 92 | Cnr Dale & Pretorius Rd
 President Park | Midrand | Gauteng
 🌐 www.zoomhandling.co.za

ZOOMLION

TECHNICAL FEATURES

- The appearance is beautiful and dynamic with large arc streamlined curved surface modeling;
- There are double motors in front wheel driving independently. The direction and speed are controlled by computer. The forklift is flexible with short turning radius;
- The batteries are arranged on the frame bottom, lowering the center of gravity and making an excellent stability;
- Batteries are in side pulling type, making the replacement more convenient;
- The good ergonomic design and ample feet working place make operation more comfortable;
- Optimized wide view mast widens the driver's vision and makes the operation safer;
- Curtis controller AC system, AC motor without carbon brush, which is free maintenance and usage cost is low;
- LED meter is easy for operation, with rich and straightforward data and information;
- The design location of control rod accords with principles of ergonomics, which is convenient for operation and relieve operator's fatigue;



- The driving and lifting are stable and accelerating is fast;
- All-direction turning design realizes the minimum turning radius;
- The adoption of oil pump with low noise reduces the noise greatly;
- Falling cushion is as standard specification to prevent the mast falling impact.

M-DUPLEX STANDARD MAST

Lifting height	Capacity			Mast height		Free lifting height	Mast Tilt
	kg			mm		mm	°
mm	1.6T	1.8T	2.0T	Forks landing	Height with Backrest	With Backrest	Angle F/R
2000	1600	1800	2000	1515	3025	81	6/6
2500	1600	1800	2000	1765	3525	81	6/6
2700	1600	1800	2000	1865	3725	81	6/6
3000	1600	1800	2000	2015	4025	81	6/6
3300	1600	1800	2000	2165	4325	81	6/6
3500	1600	1800	2000	2265	4525	81	6/6
3700	1600	1800	2000	2365	4725	81	6/6
4000	1500	1600	1800	2565	5025	81	6/6
4250	1400	1500	1700	2690	5275	81	6/6
4500	1400	1400	1600	2815	5525	81	6/6
4750	1050	1250	1400	2940	5775	81	6/6
5000	1050	1150	1350	3065	6025	81	6/6
5500	800	900	950	3365	6525	81	3/6
6000	600	750	750	3615	7025	81	3/6

S-TRIPLEX MAST

Lifting height	Capacity/kg			Mast height		Free lifting height	Mast Tilt
	kg			mm		mm	°
mm	1.6T	1.8T	2.0T	Forks landing	Height with Backrest	With Backrest	Angle F/R
3600	1500	1700	1900	1740	4590	745	6/6
4000	1300	1500	1700	1875	4990	880	6/6
4350	1250	1450	1600	1990	5340	995	6/6
4500	1200	1350	1500	2040	5490	1045	6/6
4800	1100	1250	1400	2140	5790	1145	6/6
5000	1000	1100	1300	2210	5990	1245	6/6
5500	800	900	950	2430	6490	1465	3/6
6000	600	750	750	2590	6990	1625	3/6

THREE-WHEEL ELECTRIC FORKLIFT TRUCK FE16/18/20

FEATURES		FE16	FE18	FE20
Power	—	Battery	Battery	Battery
Rated Capacity	kg	1600	1800	2000
Center of load	J(mm)	500	500	500
Lifting height	h1(mm)	3000	3000	3000
Free lifting height	h3(mm)	81	81	81
Forks L×W×H	L5×W×T(mm)	920×100×35	920×100×35	920×100×35
Tilt Forward/Backward	°	6/6	6/6	6/6
Min.turning radius	R1(mm)	1580	1580	1580
Min.ground clearance(Mast)	Ra(mm)	3275	3275	3275
ground clearance(Mast)	m(mm)	95	95	95
Overhead guard height	h4(mm)	1990	1990	1990
Front overhang	L3(mm)	375	375	375
Rear overhang	L4(mm)	194	194	194
PERFORMANCE				
Max.traveling speed(loaded)	km/h	14	14	12.5
Max.lifting speed(loaded/empty)	mm/s	320/450	300/450	290/450
Drawbar pull/Gradeability	kN/%	13.7/15	13.7/15	13.7/15
SIZE				
Overall length (with fork)	L1(mm)	2878	2878	2878
Overall width	W1(mm)	1100	1100	1100
Mast lowered height	h2(mm)	2015	2015	2015
Mast extended height	mm	4025	4025	4025
CHASSIS				
Tire Front	—	18×7-8	18×7-8	200/50-10
Tire Rear	—	15×4.5-8	15×4.5-8	15×4.5-8
Wheelbase	L2(mm)	1390	1390	1390
Tread width(Front/Rear)	S/P(mm)	940/180	940/180	940/180
Curb weight(Non-load)	kg	3050	3300	3420
ENGINE				
Battery(Voltage/Capacity)	V/Ah	48/500	48/500	48/630
Battery(Model)	—	D-450	D-450	D-630
Rated power (Walking)	kw	4.5	4.5	4.5
Rated power (Auxiliary)	kw	10	10	10
Working pressure	MPa	14.5	17.5	17.5

The company reserve the right for specification change; Should any revision on specification, a further notice shall prevail.

STANDARD CONFIGURATION			OPTIONS		ATTACHMENT	
Wideview mast	Rear lamp	Headlamp	<input type="checkbox"/> Windshield	<input type="checkbox"/> LED lamp	<input type="checkbox"/> Carpet boom	
Standard seat	Durable pneumatic tire	Adjustable steering wheel	<input type="checkbox"/> Luxury seat	<input type="checkbox"/> Rear light	<input type="checkbox"/> Hook	
Standard seat	Timer	Tilt oil passage self-locking valve	<input type="checkbox"/> Tilt cylinder dust cover	<input type="checkbox"/> File clip	<input type="checkbox"/> Lifting boom	
Backrest	Combined instrument panel	Key switch	<input type="checkbox"/> Mini fan	<input type="checkbox"/> Optional painting	<input type="checkbox"/> Hinged fork	
Reversing light	Electric Horn	Oil pressure indicator	<input type="checkbox"/> Turning Automatic speed limit	<input type="checkbox"/> Color tire (white/ green)	<input type="checkbox"/> Paper roll clamp	
Reversing buzzer	Turning signal	Toolbox	<input type="checkbox"/> Tilt/Turn cylinder cover		<input type="checkbox"/> Barrel clamp	
Rearview mirror	Service brake	Handle	<input type="checkbox"/> Low rolling resistance tyre		<input type="checkbox"/> Extended fork	
Light switch	Parking brake	Water temperature gauge	<input type="checkbox"/> Solid tyre		<input type="checkbox"/> Extended Lift Bracket	
Overhead guard	Lifting & tilting handle	Hydraulic oil return filter	<input type="checkbox"/> Fire extinguisher		<input type="checkbox"/> Load stabilizer	
2 piece multi valve	Speed limit valve	Hydraulic oil intake filter	<input type="checkbox"/> Steel Grid guard		<input type="checkbox"/> Fork cover	
Lamp bracket	Rubber pad	Hydraulic oil level gauge	<input type="checkbox"/> Rotary work alarming light		<input type="checkbox"/> Revolving Flat Clamps	
					<input type="checkbox"/> Wide view duplex/triplex full free mast	