

ZOOMLION

ELECTRIC ARTICULATING BOOM LIFT ZA20JE

Comply with CE/ANSI/CSA Standard



HIGHLIGHTS

- ▶ Provide greater work height of 21.45m (70ft 4in) and lift capacity of 250kg (550 lb) than competitor
- ▶ Fast lift system directly lowers the boom from the highest position to the ground, no need to fold the boom to improve work efficiency.
- ▶ Accurate and efficient traveling AC drive system and on-board motion AC drive system provides strong power, stable control and maintenance-free motor.
- ▶ Independent auxiliary power system for more secure application



FEATURES

Standard Features

- | | |
|--------------------------|-----------------------------|
| Proportional control | Emergency stop button |
| All motion alarm | Auto-leveling system |
| Flashing amber beacon | On-board diagnostic system |
| Self-closing entry gate | Over tilt protection system |
| Emergency descent system | Oscillating axle |

- | |
|---------------------------|
| Load sensing system |
| 4.3' LED display |
| Horn |
| Secondary Guarding System |

Accessories & Options

- | |
|-------------------------------|
| AC power to platform |
| Air line to platform |
| Non-marking tire |
| Low-temperature hydraulic oil |

ACCESS WITH ZOOMLION GREEN

Phone: 0086(731)-88353680 0086(731)-88250971
E-mail: awm@zoomlion.com

Add: ZOOMLION Wangcheng Industrial Park, Tengfei Road 997, Changsha, Hunan, China
Web: www.en.zoomlion.com

ZOOMLION

ELECTRIC ARTICULATING BOOM LIFTS

ZA20JE

Comply with CE/ANSI/CSA Standard

Model	ZA20JE	
	Imperial	Metric
Size		
Work Height	70ft 4in	21.45m
Platform Height	63ft 10in	19.45m
Horizontal Outreach	39ft 6in	12.05m
Up and Over Height	27ft 1in	8.25m
A - Stowed Length	28ft 7in	8.72m
B - Stowed Width	8ft 1in	2.46m
C - Stowed Height	8ft 3in	2.52m
D - Platform Length	6.00ft (standard) 8.01ft (option)	1.83m (standard) 2.44 (option)
E - Platform Width	2.49ft (standard) 2.99ft (option)	0.76m (standard) 0.91 (option)
Jib Length	5ft	1.53m
F - Wheelbase	8ft 3in	2.52m
G - Ground Clearance	1ft 1in	0.33m
Performance		
Platform Capacity	550 lb	250kg
Drive Speed	3.79 mph	6.1km/h
Gradeability	45%(24°)	
Axles Oscillation	8in	0.20m
Turning Radius (Inside)	9ft 1in	2.78m
Turning Radius (Outside)	18ft	5.49m
Swing	360° continuous/400° non-continuous	
Platform Rotation	±90°	
H-Tail Swing	2ft	0.6m
Max. Wind Speed	28mph	12.5m/s
Power		
Battery	24×2V/440Ah	
Charger	48V/60A	
Drive Motor	AC 32V/4.4hp	AC 32V/3.3kW
Lift Motor	AC 32V/13.4hp	AC 32V/10kW
Auxiliary Power	12V DC	
Hydraulic Tank Capacity	19.8 (us gal)	75L
Drive	4WD	
Tire		
Type	33×12 D610 Foam-filled Tires	
Weight		
Gross	20283 lb	9200kg

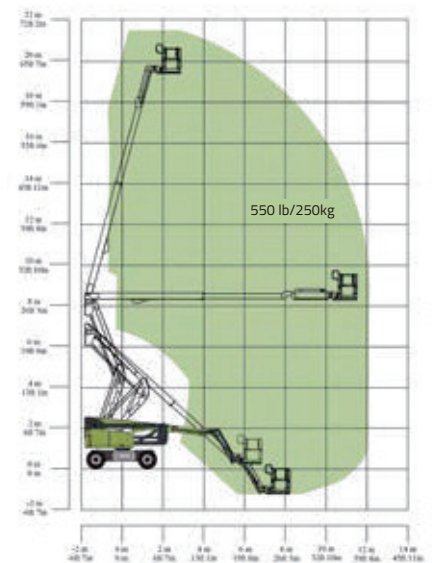
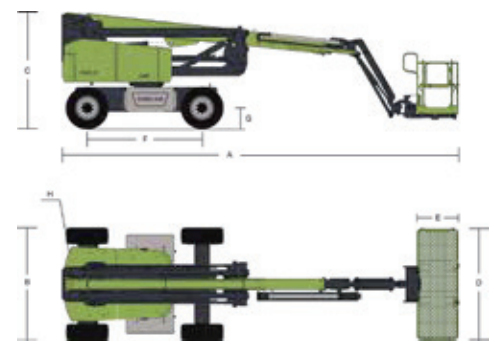

Range of Motion ZA20JE